

Model PC420V explosion proof Series Velocity loop powered sensors (LPS™)

Features

- Peak equivalent or RMS or True Peak
- Explosion proof certification
- Corrosion resistant
- ESD protection
- Overload protection
- Reverse wiring protection

Benefits:

- Choice of output: RMS, True Peak, and Peak, permits you to choose the sensor that best fits your industrial requirements
- Provides continuous trending of overall machine vibration
- True peak is useful for detecting loose parts like valves on reciprocating machinery
- Can help guide maintenance
- Helps notify of impending equipment failure
- Hazardous area installation

The output of the PC420V Series is proportional to velocity vibration. An output of 4 mA indicates a level of 0 IPS or no vibration present. A full-scale reading of 20 mA indicates that the maximum range (Peak or RMS) of vibration is present. The Peak output units provide a computed equivalent peak level of vibration based on the RMS.

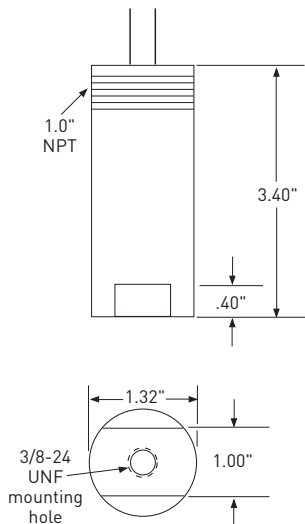

Output, 4-20 mA

Full scale, 20 mA (±5%)	see Table 1 on back
Frequency response:	
±10%	10 Hz - 1.0 kHz
±3 dB	4 Hz - 2 kHz
Repeatability	±2%
Transverse sensitivity, max.....	5%

Electrical

Power requirements (two wire loop power):

Voltage at PC420-series sensor terminals	14 VDC min, 30 VDC max
Loop resistance ¹ at 24 VDC, maximum.....	700Ω
Turn on time, 4-20 mA loop.....	< 10 seconds
Grounding.....	case isolated, internally shielded

Environmental

Temperature range	-40 to 85°C
Vibration limit	250 g peak
Shock limit	2,500 g peak
Sealing	epoxy sealed

Physical

Sensing element design	PZT ceramic / shear
Weight	380 grams
Case material	303 stainless steel
Mounting	3/8-24 x 3/8 depth tapped hole
Output leads, 18 AWG	4 meters long

Cable	Function
Red	loop positive (+)
White	loop negative (-)

Accessories supplied: SF20-2 mounting stud (International customers specify mounting requirements); calibration data (level 2).

Wilcoxon Research Inc
21 Firstfield Rd
Gaithersburg, MD 20878
USA

Tel: 301 330 8811
Fax: 301 330 8873
Email: sensors@wilcoxon.com

www.meggitt.com



Table 1: PC420Vx-yy-EX explosion proof model number selection

x (4-20 mA output type)	yy (4-20 mA full scale)
R = RMS output, velocity	05 = 0.5 IPS
P = Equivalent peak output, velocity	10 = 1.0 IPS
TP = True peak output, acceleration	20 = 2.0 IPS
	30 = 3.0 IPS
	50 = 5.0 IPS

Notes: ¹ Maximum loop resistance (R_L) can be calculated by:

$$R_L \text{ (max resistance)} = \frac{V_{DC \text{ power}} - 10 \text{ V}}{20 \text{ mA}}$$

DC supply voltage	R_L (max resistance) ²	R_L (minimum wattage capability) ³
12 VDC	100Ω	1/8 Watt
20 VDC	500Ω	1/4 Watt
24 VDC	700Ω	1/2 Watt
26 VDC	800Ω	1/2 Watt
30 VDC	1.0kΩ	1/2 Watt

² Lower resistance is allowed, greater than 10Ω recommended.

³ Minimum R_L wattage determined by: $(0.0004 \times R_L)$.

Typical circuit

