



Model PC420V series Velocity loop powered sensors (LPS™)

Features

- Peak equivalent, true RMS or true peak output
- Corrosion resistant
- Hermetic seal
- ESD protection
- Overload protection
- Reverse wiring protection

Benefits

- Choice of output: RMS, true peak, or peak, permits you to choose the sensor that best fits your industrial requirements
- Provides continuous trending of overall machine vibration
- True peak is useful for detecting loose parts like valves on reciprocating machinery
- Can help guide maintenance
- Helps notify of impending equipment failure

The 4-20 mA output of the PC420V Series is proportional to velocity vibration. An output of 4 mA indicates a level of 0 ips or no vibration present. A full-scale reading of 20 mA indicates that the maximum range (Peak or RMS) of vibration is present.

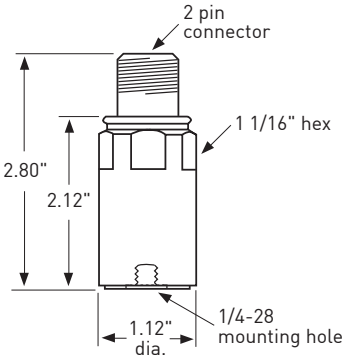

Output, 4-20 mA

Full scale, 20 mA (±5%)	see table 1 on back
Frequency response:	
±10%	10 Hz - 1.0 kHz
±3 dB	4 Hz - 2 kHz
Repeatability	±2%
Transverse sensitivity, max.	5%

Electrical

Power requirements (two wire loop power):

Voltage at PC420 seriessensor terminals	10 VDC min, 30 VDC max
Loop resistance ¹ at 24 VDC, maximum	700Ω
Turn on time, 4-20 mA loop	30 seconds
Grounding	case isolated, internally shielded

Environmental

Temperature range	-40 to 85°C
Vibration limit	250 g peak
Shock limit	2,500 g peak
Sealing	hermetic

Physical

Sensing element design	PZT ceramic / shear
Weight	162 grams
Case material	316L stainless steel
Mounting	1/4 - 28 tapped hole
Output connector	2 pin, MIL-C-5015 style
Mating connector	R6 type
Recommended cabling	J9T2A

Connector pin	Function
Shell	ground
A	loop positive (+)
B	loop negative (-)

Accessories supplied: SF6 mounting stud (International customers specify mounting requirements); calibration data (level 2)

Wilcoxon Research Inc
20511 Seneca Meadows Parkway
Germantown, MD 20876
USA

Tel: 301 330 8811
Fax: 301 330 8873
Email: sensors@wilcoxon.com

www.meggitt.com



MEGGITT
smart engineering for
extreme environments
98826 Rev.A.6 04/07

Table 1: PC420Vx-yy model number selection

x (4-20 mA output type)	yy (4-20 mA full scale)
R = RMS output, velocity	05 = 0.5 ips
P = equivalent peak output, velocity	10 = 1.0 ips
TP = true peak output, velocity	20 = 2.0 ips
	30 = 3.0 ips
	50 = 5.0 ips

Notes: ¹ Maximum loop resistance (R_L) can be calculated by:

$$R_L \text{ (max resistance)} = \frac{V_{\text{DC power}} - 10 \text{ V}}{20 \text{ mA}}$$

DC supply voltage	R_L (max resistance) ²	R_L (minimum wattage capability) ³
12 VDC	100Ω	1/8 watt
20 VDC	500Ω	1/4 watt
24 VDC	700Ω	1/2 watt
26 VDC	800Ω	1/2 watt
30 VDC	1.0kΩ	1/2 watt

² Lower resistance is allowed, greater than 10Ω recommended.

³ Minimum R_L wattage determined by: $(0.0004 \times R_L)$.

Typical circuit

